



Patriot[®] **40**

OPERATIONS MANUAL

Care & Maintenance Instructions

- Do not discard this manual.
- Keep manual readily available for reference during operation or when servicing product.
- Before operation and maintenance, read and comprehend operations manual content.

- **Customer Service:** 800.356.NUMA or 860.923.9551
- **Email:** numa@numahammers.com
- **Website:** www.numahammers.com
- **Mailing Address:** P.O. Box 348, Thompson, CT 06277 USA

Patents: 6,883,618 7,442,074 10,612,310 11,085,242 EP 3 803 032 B1 KR-101340351 EP-2029325
CN-101448608 BR-P10711711 AU2007254317 AU2007254317 WO2007/136658

TABLE OF CONTENTS

	Page
Section I Description	1
Functional Description.....	2
1. Backhead.....	2
2. Pin	2
3. Check Valve.....	2
4. Check Valve Spring	2
5. Plug.....	2
6. Choke.....	2
7. Feed Tube	2
8. Piston.....	2
9. Case	3
10. Snap Ring	3
11. Bit Bearing.....	3
12. Bit Retaining Rings.....	3
13. Chuck.....	3
 Section II Maintenance	 4
Disassembly.....	4
Inspection.....	6
General Assembly	8
Hammer Assembly	9
Backhead / Feed Tube Assembly	9
 Section III Parts Identification	 10
Patriot 40 Exploded View.....	10
Part Number Reference.....	10
 Section IV Air Consumption Charts.....	 11
 Section V Lubrication	 12
 Section VI Storage	 13
Short Term.....	13
Long Term	13
Restarting.....	14
 Section VII Button Bit Maintenance	 15
General	15
Sharpening.....	15
 Section VIII Patriot 40 Recommended Spares.....	 16



NUMA[®]
HAMMERS AND BITS
WARRANTIES AND REMEDIES

LIMITED WARRANTY

Numa warrants that the Product will be new and free from defects in material and workmanship under normal use as contemplated by this Contract for a period of six (6) months from the date of shipment.

Except for the foregoing warranty, Numa disclaims all warranties and representations wherever made, including warranties of merchantability, durability, length of service, or fitness for a particular purpose.

Any alteration or modification of the original product without the express written consent of Numa will void this warranty.

REMEDY

If, during such warranty period, Buyer promptly notifies Numa in writing of any defect and establishes that the above warranty is not met, Numa shall either repair or replace the Product or credit the customer, as it deems necessary to meet the warranty.

Such repair, replacement, or credit of Product shall constitute complete fulfillment of Numa's obligation under this warranty, and upon the expiration of the original warranty period, all of Numa's obligations hereunder shall terminate.

LIMITATION OF LIABILITY

Numa shall not be liable to Buyer whether in contract, in tort (including negligence and strict liability), under any warranty or otherwise, for any special, indirect, incidental or consequential loss or damage whatsoever, including (without limitation) loss arising from delay, cost or capital and loss of profits or revenues. The remedies set forth in this Contract are exclusive, and the total cumulative liability of Numa under this Contract or for any act or omission in connection therewith or related thereto, whether in contract, in tort (including negligence and strict liability), under any warranty or otherwise, is limited to the price paid by Buyer for the Product.

The **WARNINGS**, **CAUTIONS** and **NOTES** used throughout the text of this instruction book are defined as follows:

WARNING	A specific procedure or practice that must be strictly followed, or a specific condition that must be met, to prevent possible bodily harm.
CAUTION	A specific procedure or practice that must be strictly followed, or a specific condition that must be met, to prevent damage to the equipment.
NOTE	Important supplemental information.

Numa[®], Champion[®], and Patriot[®] are registered trademarks of Numa.

SECTION I DESCRIPTION

GENERAL DESCRIPTION

The Patriot 40 is a valveless, pneumatically operated tool designed to utilize Numa 4-1/4" to 5-1/4" (108 mm to 133 mm) diameter bits in rock formations under a wide range of operating conditions.

The Patriot 40 hammer design incorporates a hardened reversible case. The single bore design allows for a maximum bore diameter in conjunction with optimum life against abrasion. The simple design of the Patriot 40 provides performance and dependability without sacrificing tool life.

The Patriot 40 is designed for universal applications using air pressure from 150 PSI to 500 PSI (10.2 Bar to 34.5 Bar) with compressors having capacities of 140 CFM (66 Litres/Second) or more. When drilling conditions require supplementary hole cleaning, additional hole cleaning air can be passed through the hammer by utilizing an interchangeable choke. All standard hammers shipped from Numa have a blank choke installed. Refer to page 11 for correct choke selection and pages 5 and 9 to facilitate the removal and the installation of the choke.

<i>Patriot 40</i>		
Weight w/o Bit	78 lbs.	(35 kg)
Outside Diameter	3-3/4"	(95 mm)
Hammer Length:		
Shoulder to Shoulder	36-1/8"	(92 cm)
Shoulder to Bit Face	39-3/8"	(100 cm)
Backhead API Thread	2-3/8 API REG	

Table 1-1 General Hammer Specifications

4-1/4"	(108 mm)	18 lbs.	(8.2 kg)
4-1/2"	(114 mm)	19 lbs.	(8.6 kg)
4-3/4"	(121 mm)	20 lbs.	(9.1 kg)
5"	(127 mm)	21 lbs.	(9.5 kg)
5-1/8"	(130 mm)	21 lbs.	(9.5 kg)
5-1/4"	(133 mm)	22 lbs.	(10.0 kg)

Table 1-2 General Bit Specifications

NOTE

NUMA 4-1/4" TO 5-1/4" (108 MM TO 133 MM) BITS ARE AVAILABLE IN CONCAVE, CONVEX OR FLAT FACE DESIGNS WITH LARGE AIR FLUSHING HOLES AND CHIP WAYS TO TAKE ADVANTAGE OF THE PATRIOT 40 PERFORMANCE. OTHER SIZES MAY BE AVAILABLE UPON REQUEST.

FUNCTIONAL DESCRIPTION

1. BACKHEAD

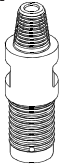

The backhead connects the hammer to the drill rod. It is threaded into the top end of the case with double start threads and into the drill rod with a standard 2-3/8 API REG thread. Wrench flats are provided for disassembling.

2. PIN



The pin aligns the feed tube assembly into the backhead. It is made of hardened steel to insure long life.

3. CHECK VALVE



The check valve maintains pressure in the hammer when the air supply has been shut off. The pressure in the hammer balances the hydrostatic pressure in the hole thereby preventing contaminants from entering the hammer.

4. CHECK VALVE SPRING



The check valve spring provides tension under the check valve to keep it closed. It is compressed as the air is turned on.

5. PLUG



The plug is seated in the feed tube and maintains the proper location of the check valve and check valve spring.

6. CHOKE



The interchangeable choke is located in the tip of the feed tube and is held in place with a press fit. A set of three chokes is supplied with each hammer. By installing the correct choke, the hammer can be fine tuned to the compressor package.

7. FEED TUBE



The feed tube supplies the main air into the chambers located in the piston. It is connected to the backhead by the pin. The feed tube is designed with a long bearing surface to maintain alignment in the backhead.

8. PISTON

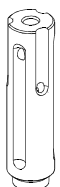

The piston functions as the only moving part in the hammer, controlling the operational air cycle. The percussive action of the piston striking the bit transfers the energy through the bit in order to fracture rock formations. A snap ring inserted in the main bore prevents the piston from sliding out of the case when the chuck, bit, bit retaining rings and bit bearing are removed.

9.  **CASE**

The case is designed to contain the internal parts which make up the hammer assembly. The case is reversible and hardened to resist wear and to extend life in abrasive conditions. Double start threads on each end of the case allow for ease of disassembly.

10. **SNAP RING**



A snap ring positions the internal parts in the hammer and prevents the piston from falling out when the chuck, bit retaining rings and bit are removed.

11. **BIT BEARING**



The bit bearing guides the bit to insure proper alignment between the piston and the bit. The bit bearing is placed into the chuck end of the case and is located by a snap ring which is inserted into the main bore.

12. **BIT RETAINING RINGS**



The bit retaining rings are designed to allow the bit to move between the drilling and cleaning positions and prevent the bit from coming completely out of the hammer. The bit retaining rings consist of two matched halves and are held together with the bit retaining ring o-ring.

13. **CHUCK**

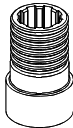

The chuck threads into the bottom end of the case with double start threads. It has internal splines that mesh with the splines on the bit body to transmit rotation.

SECTION II MAINTENANCE

DISASSEMBLY

- If at all possible, the backhead and chuck should be broken loose on the drill rig; this is much easier than trying to do so after the drill has been removed from the drill rig.

CAUTION

USE CAUTION WHEN HANDLING DOWN THE HOLE HAMMER PARTS. NUMA HAMMER PARTS ARE MANUFACTURED FROM HARDENED, HEAT TREATED MATERIALS. DROPPING OR STRIKING THESE PARTS MAY CAUSE SEVERE DAMAGE. STRIKING THE HAMMER PARTS WITH HAMMERS, CROWBARS OR LIKE INSTRUMENTS WILL VOID THE WARRANTY.

- Maintenance should be performed in a clean environment.
- Tools needed: hammer stand, chain vise, 2" (51 mm) diameter brass rod, a drift pin, a small screwdriver and a 3/8" (10 mm) diameter 24" (610 mm) long steel rod.
- Clean the outside of the hammer. This will insure a good surface to clamp on.
- Place the hammer horizontally on a hammer stand and secure the hammer with a chain vise. Place the chain vise on the area of the case where the bit bearing is housed when working on the chuck end of the hammer.

CAUTION

THE ACCEPTABLE CLAMPING AREAS START 4" (102 MM) FROM EITHER CASE END, TO AN ADDITIONAL 1.5" (38 MM) BEYOND THIS POINT. PLACING THE CHAIN VISE ON THE AREA OF THE CASE WHERE THE PISTON CYCLES CAN DISTORT THE CASE, RESTRICT PISTON MOVEMENT AND VOID THE WARRANTY.

- Unscrew the backhead / feed tube assembly from the case.
- Slide the piston out of the case.
- Unscrew the chuck and remove from the case.
- Remove the bit retaining rings from the case. Remove the bit retaining rings o-ring from the bit retaining rings.

- Removal of the bit bearing and the snap ring in the chuck end is not necessary for routine maintenance. If necessary, slide the bit bearing out the chuck end of the case. Slide the piston into the backhead end of the case with the serial number of the piston facing the chuck end of the case. With a 2" (51 mm) diameter brass rod, tap or press on the piston to remove the snap ring.
- To disassemble the backhead / feed tube assembly, stand the backhead / feed tube assembly on a bench, with the API thread facing down.
- Using a drift pin, tap the pin out of the backhead / feed tube assembly.
- Lift the feed tube assembly out of the backhead.
- Remove the feed tube o-ring from the backhead.
- Removal of the plug and choke are not necessary for routine maintenance. If necessary, use a 3/8" (10 mm) diameter, 24" (610 mm) long rod and tap the choke downward, toward the plug. Continue tapping both the feed tube plug and choke out of the feed tube.
- Remove the backhead o-ring from the backhead.
- Remove the check valve and check valve spring from the backhead.

INSPECTION

- All parts should be washed in a clean solvent before they are inspected and reassembled.

WARNING
USE CLEANING FLUIDS THAT ARE NONFLAMMABLE AND AVOID
BREATHING THE FLUID VAPORS.

- Handle all parts carefully, hardened parts may chip if dropped on a hard surface.

BACKHEAD

- Inspect the threads and pin hole for cracks and burrs.
- Remove all burrs on the thread with a fine file.
- Replace if necessary.

CHECK VALVE

- The check valve should be smooth and free from abrasions.
- Replace if necessary.
- Replace the check valve spring if it is worn or broken.

FEED TUBE

- Inspect the outside diameter for nicks, burrs and scoring.
- Inspect all makeup surfaces for indentations or nicks caused by wear.
- Remove all minor irregularities with emery cloth.
- Replace if necessary.

PIN

- Inspect pin for scoring or cracks.
- Replace if necessary.

SNAP RING

- Inspect the snap ring for severe wear indications.
- Remove or round over any sharp edges.
- Replace if necessary.

PISTON

- Inspect the striking face, inside and outside diameters for nicks, scoring and cracks.
- Polish the piston with emery cloth to remove all minor irregularities, cracked pistons should be replaced.
- Wash the piston thoroughly, inside and out, to remove all emery dust.

CASE

- Inspect the outside diameter for excessive wear or cracks. Inspect the internal case bore for scoring.
- Remove all minor irregularities with fine honing stones.
- Clearance between the piston and the case should not exceed 0.011" (0.28 mm).
- Select the larger diameter end of the case to be the chuck end. Replace if the outside diameter is worn to 3-1/2" (89 mm) or less near the chuck end.

BIT BEARING

- Inspect the inside and outside for nicks and burrs.
- Remove all internal irregularities with a fine honing stone.
- Remove all external irregularities with an emery cloth.
- Clearance between the bit shank and bit bearing should not exceed 0.010" (0.25 mm).
- Replace if necessary.

BIT RETAINING RINGS

- Inspect for cracks or deformations.
- Remove all irregularities with a file or emery cloth.
- Replace if necessary.

CHUCK

- Inspect for cracks and burrs.
- For continued use, the outside diameter should be larger than the outside of the case or the same. Collar length should not be less than 1-7/8" (48 mm).

CAUTION

IF THE COLLAR LENGTH IS LESS THAN 1-7/8" (48 MM) AND THE BIT IS UNDER LOAD CONDITIONS, CONTACT BETWEEN THE SHOULDER OF THE BIT RETAINING RINGS AND THE BOTTOM OF THE BIT RETAINING RING AREA ON THE BIT, COULD CAUSE THE BIT TO FAIL IN THIS AREA.

- Torsional play in the splines should not exceed 0.125" (3.2 mm).
- Replace if necessary.

O-RINGS

- Inspect for damage such as cracks and deformations.
- Replace if necessary.

GENERAL ASSEMBLY INSTRUCTIONS

- Assembly should be performed in a clean environment.
- All parts should be cleaned thoroughly and wiped dry before assembly.
- Oil all parts by hand using Rock Drill Oil to insure easy assembly.
- Coat all thread connections with a thread compound to allow joints to thread easily.

HAMMER ASSEMBLY

- Select the larger, outside diameter end of the case to be the chuck end.
- Insert the snap ring into the groove located in the chuck end of case, making sure it seats properly in the groove.
- Slide the bit bearing in the chuck end of the case, square end into the case first. Make sure it is in contact with the snap ring. Install the bit bearing retainer o-ring in the groove in front of the bit bearing.
- Insert the bit retaining rings, with the o-ring installed, in the chuck end of the case.
- Thread the chuck into the case and hand tighten. The chuck shoulder should sit flat against the bottom of the case.
- Slide the piston in the backhead end of the case. Push the piston all the way to the chuck end. The piston should ride in the case very smoothly.

BACKHEAD / FEED TUBE ASSEMBLY

- Place the backhead on the bench with the API threads facing down. Install the backhead o-ring into the groove located on the outside diameter.
- Place the feed tube o-ring into the groove located on the outside diameter of the feed tube.
- Place the check valve and check valve spring in the backhead.
- Drop the choke into the feed tube and using the small rod, tap the choke in place.
- Using a drift pin, tap the plug into the feed tube until it seats against the shoulder.
- Using a rubber mallet, tap the feed tube into the backhead, aligning the hole on the feed tube with the hole in the backhead.
- Using a rubber mallet, tap the backhead / feed tube pin into the hole, seating it through both the feed tube and backhead equally.
- Screw the backhead into the case.

CAUTION

DUE TO CLOSE TOLERANCES BETWEEN THE PATRIOT 40 INTERNAL PARTS AND THE CASE, NUMA CAN NOT ACCEPT RESPONSIBILITY FOR DAMAGE CAUSED BY WELDING ON THE CASE OD. WELDING ON THE CASE CAN CREATE DISTORTION, CAUSE PREMATURE FAILURE AND VOID THE WARRANTY. CONTACT NUMA FOR SPECIAL INSTRUCTIONS IF WELDING THE CASE BECOMES UNAVOIDABLE.

SECTION III PARTS IDENTIFICATION EXPLODED VIEW

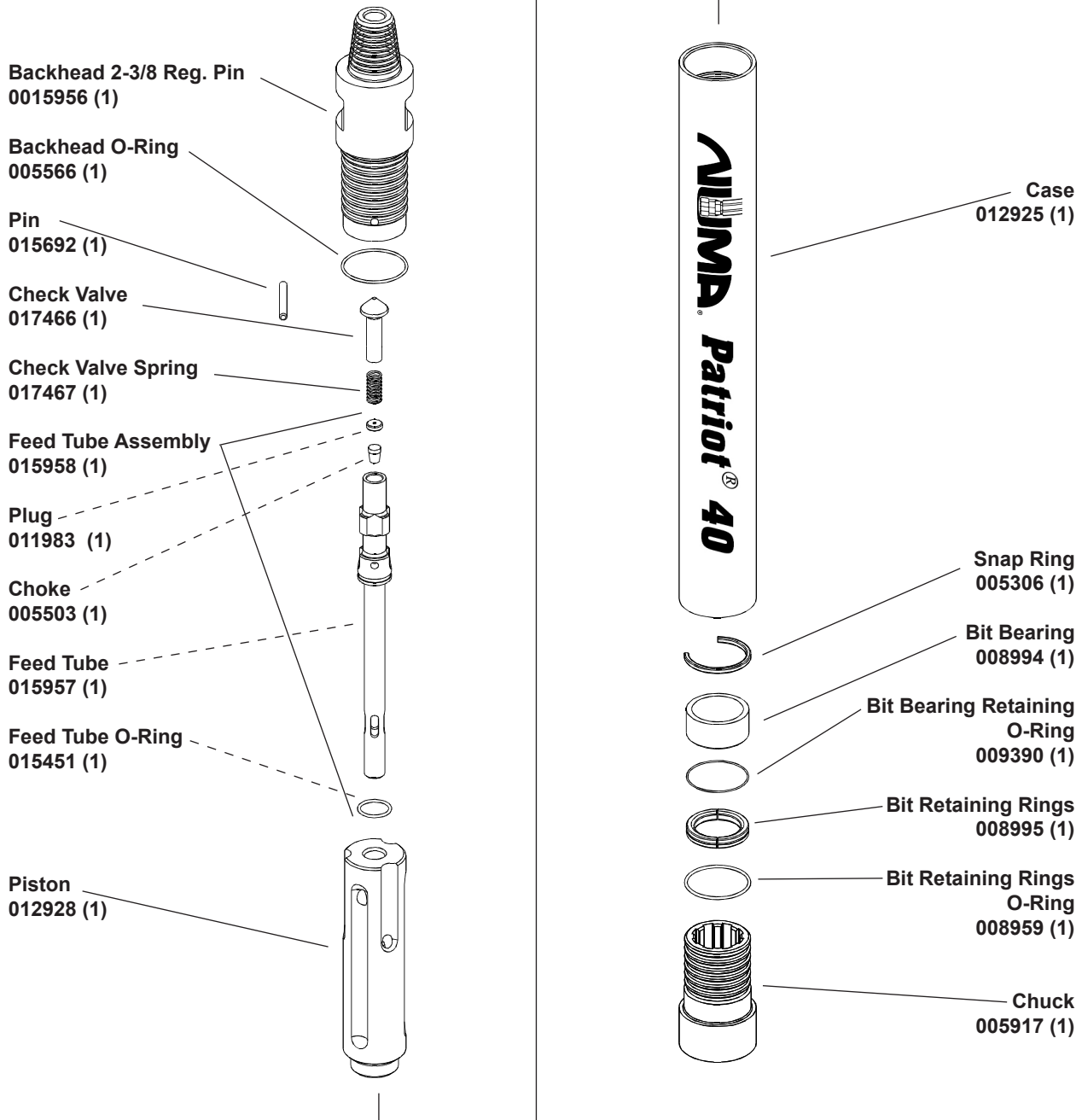

Hammer Assembly #015959
Figure 3-1

SECTION IV AIR CONSUMPTION CHARTS PATRIOT 40

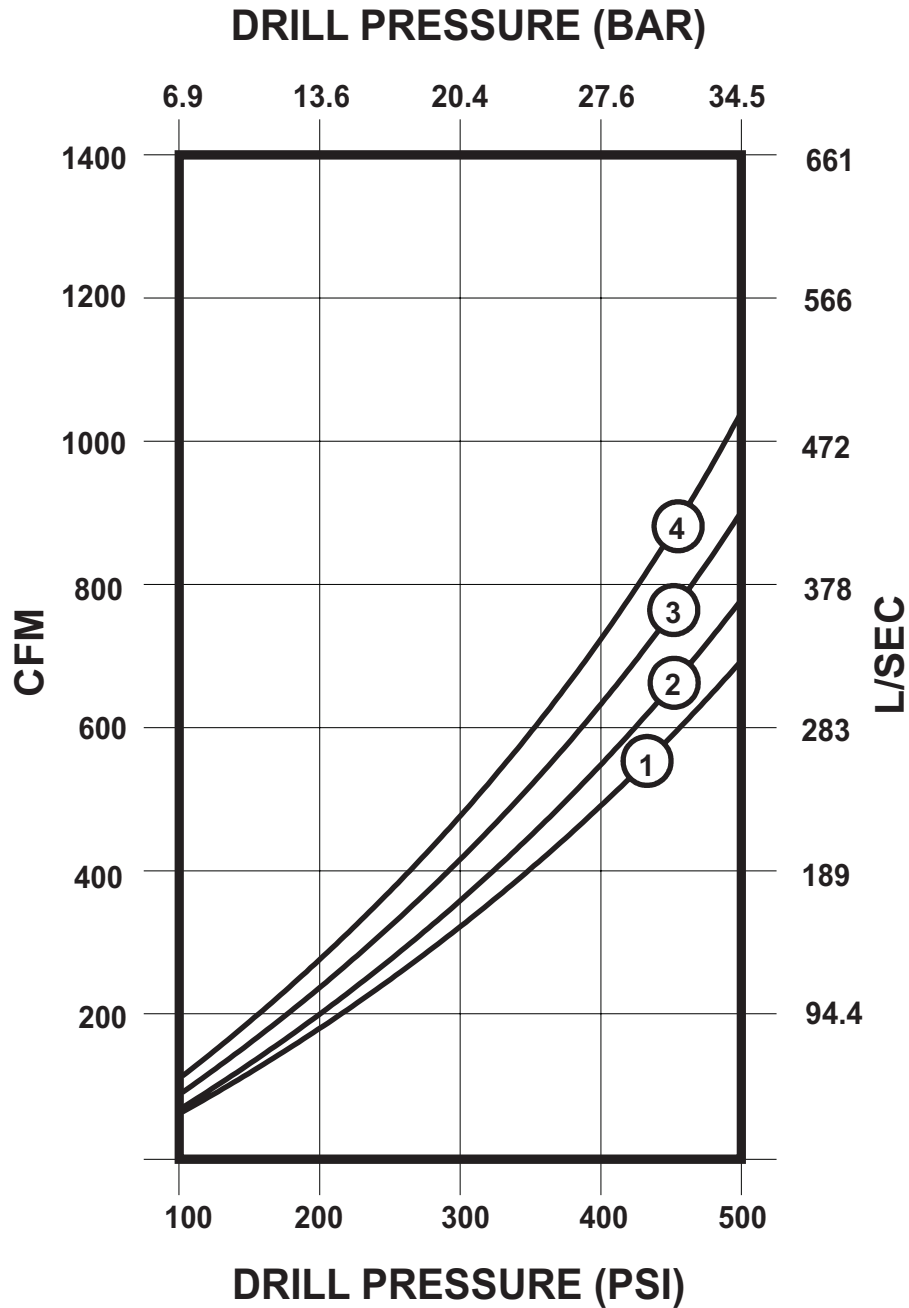

- ① SOLID CHOKE
- ③ 3/16 (4.8mm) CHOKE
- ② 1/8 (3.2mm) CHOKE
- ④ 1/4 (6.4mm) CHOKE

SECTION V LUBRICATION

The Patriot 40 hammer requires a continuous supply of the correct type Rock Drill Oil or an adequate application of Numa Enviro Lube. The Patriot 40 hammer consumes at least one quart (1 litre) of Rock Drill Oil per hour in order to maintain adequate lubrication. See table 5-1 for recommended Rock Drill Oil.

As an alternative to Rock Drill Oil, Numa Enviro Lube provides continuous protection for the Patriot 40 when 3 oz. (.09 litres) are used every 300' (92 m) or four hours of drilling, whichever occurs first. Numa Enviro Lube is utilized in 3-1/2" to 6" hammers only.

	Medium SAE 30	Heavy SAE 50
Shell	Air Tool Oil S2 A 150	Air Tool Oil S2 A 320
Texaco / Caltex	Rock Drill Lube 100	Rock Drill Lube 320
Chevron	Vistac 150	Vistac 320
Conoco	Conoco 150	Conoco 320
Numa Bio Blend	RDP 150	RDP 320

Table 5-1
Recommended Rock Drill Oil

CAUTION

ROCK DRILL OILS AND NUMA ENVIRO LUBE ARE THE ONLY ACCEPTABLE LUBRICANTS. SAE 50 ROCK DRILL OIL SHOULD BE USED IN AMBIENT TEMPERATURES OF 80° FAHRENHEIT (27° CELSIUS) OR HIGHER. CONTACT NUMA FOR ACCEPTANCE OF ALTERNATIVE ROCK DRILL LUBRICANTS.

CAUTION

THE PATRIOT 40, AS WITH ANY MACHINE, REQUIRES CONTINUOUS LUBRICATION. THE FAILURE TO SUPPLY ADEQUATE LUBRICATION TO THE HAMMER CAN CAUSE PREMATURE FAILURE AND MAY VOID THE WARRANTY.

SECTION VI STORAGE

When storing a Patriot hammer, it is important to take the necessary steps in order to insure a smooth operation after restarting.

When the hole is completed and the hammer is to be inactive for several weeks or longer the following steps should be followed:

Each drill rod should be blown clear of all water. During this process, turn on the in line lubricator and blow until the rock drill oil can be seen from the bottom end of each drill rod. In addition, each rod (pin and box end) should be wiped clean and capped to prevent foreign contaminants from sticking to the connector ends.

SHORT TERM STORAGE

When the Patriot hammer will be stored for only a short period of time the following steps should be taken:

- Blow the hammer clear of all water.
- Pour one cup of Rock Drill Oil into the backhead.
- Turn the air on and cycle for 10 seconds. This will lubricate the internal parts.
- Cap the backhead and chuck end.
- Store the hammer horizontally in a dry environment.

LONG TERM STORAGE

When the Patriot hammer will be stored for a long period of time the following steps should be taken:

- Blow the hammer clear of all water.
- If at all possible, the backhead and chuck should be broken loose on the drill rig, this is much easier than trying to do so in the shop.
- Disassemble the hammer.
- Inspect and wipe all the parts clean.

- Lubricate all the internal parts with Rock Drill Oil. See table 5-1 on page 12 for suitable Rock Drill Oils.
- Cap the backhead and chuck ends.
- Store the hammer horizontally in a dry environment.

RESTARTING

Before restarting the hammer after prolonged periods of inactivity, disassemble and inspect all internal hammer parts.

If any internal hammer parts have oxidized, use an emery cloth to polish each part. Wash each hammer part, wipe dry, relubricate with rock drill oil and reassemble the hammer.

CAUTION

**FAILURE TO CHECK INTERNAL PARTS BEFORE RESTARTING THE HAMMER
MAY CAUSE SERIOUS DAMAGE TO THE HAMMER.**

SECTION VII BUTTON BIT MAINTENANCE

GENERAL

Numa button bits are designed for fast penetration and long life. Keeping the carbide buttons sharp has a direct effect on both the penetration and the tool life.

As the bit wears flat, spots develop on the carbide buttons. These flat spots increase stress on the buttons causing the bit to work harder, which may cause button failure. Bit sharpening can minimize these problems.

Gauge buttons will usually show the most wear and should be used to determine the frequency of bit sharpening. When the flats on the gauge buttons become a maximum of 1/8" (3 mm) wide it is time to resharpen. Refer to figure 7-1.

SHARPENING

The following tools are required to resharpen the bit:

- Hand grinder (20,000 r.p.m.)
- Silicon carbide wheel 1" (25 mm) diameter, 60 - 80 grit
- Bit stand
- Pencil

Place a mark on the center of the button flat. Grind the button to its original shape leaving the mark untouched. Refer to figure 7-1. It is important to leave the center of the flat untouched to insure concentricity.

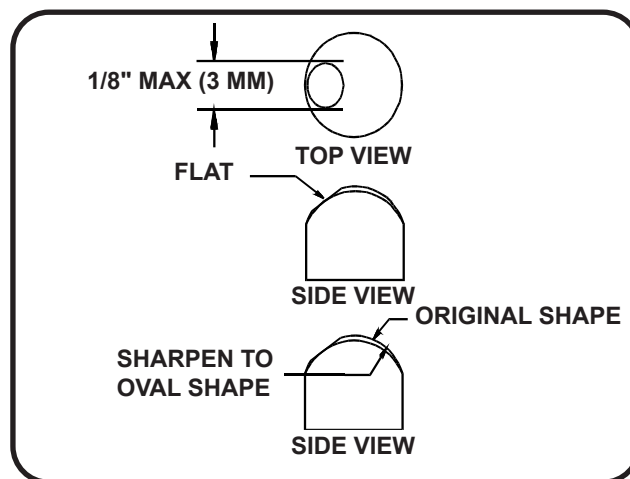

Button Resharpening
Figure 7-1

SECTION VIII RECOMMENDED SPARES Patriot 40

Product Description	Part Number	Class 1	Class 2
Backhead 2-3/8 Reg Pin	015956	0	1
Backhead O-Ring	005566	2	4
Pin	015692	1	2
Check Valve	017466	1	2
Check Valve Spring	017467	1	2
Feed Tube Assembly	015958	1	2
Plug	011983	1	2
Choke Blank	005503	0	1
Feed Tube	015957	1	2
Feed Tube O-Ring	015451	2	4
Piston	012928	0	1
Case	012925	0	1
Snap Ring	005306	1	2
Bit Bearing	008994	0	1
Bit Bearing Retaining O-Ring	009390	1	2
Bit Retaining Rings	008995	1	2
Bit Retaining Ring O-Ring	008959	1	2
Chuck	005917	1	2
Choke Set	007108	1	2
Choke Blank - installed in hammer	005503	0	1
Choke 1/8"	007110	0	1
Choke 3/16"	007111	0	1
Choke 1/4"	007112	0	1

*For Complete Hammer Assembly #015959
Table 8-1*

NOTE

- | | |
|---------|--|
| Class 1 | Represents a user of a Patriot 40 hammer that has readily available spare parts. |
| Class 2 | Represents a user of a Patriot 40 hammer that does not have readily available spare parts. |

NOTES

NOTES