



Patriot® **240**

OPERATIONS MANUAL

Care & Maintenance Instructions

- Do not discard this manual.
- Keep manual readily available for reference during operation or when servicing product.
- Before operation and maintenance, read and comprehend operations manual content.

- **Customer Service:** 800.356.NUMA or 860.923.9551
- **Email:** numa@numahammers.com
- **Website:** www.numahammers.com
- **Mailing Address:** P.O. Box 348, Thompson, CT 06277 USA

Patents: 6,883,618 7,442,074 10,612,310 11,085,242 EP 3 803 032 B1 KR-101340351 EP-2029325
CN-101448608 BR-P10711711 AU2007254317 AU2007254317 WO2007/136658

TABLE OF CONTENTS

	Page
Section I Description	1
Functional Description.....	2
1. Backhead.....	2
2. Pin	2
3. Check Valve.....	2
4. Check Valve Spring	2
5. Choke.....	2
6. Plug.....	2
7. Feed Tube Bushing.....	2
8. Feed Tube	2
9. Piston.....	3
10. Case	3
11. Bit Bearing.....	3
12. Snap Ring	3
13. Bit Retaining Rings.....	3
14. Thrust Washers - Brass.....	3
15. Chuck.....	3
16. Chuck Bushing	3
 Section II Maintenance	 4
Disassembly.....	4
Inspection.....	7
General Assembly	10
Hammer Assembly	10
Backhead / Feed Tube Assembly	11
 Section III Parts Identification	 12
Patriot 240 Exploded View.....	12
Part Number Reference.....	12
 Section IV Air Consumption Charts.....	 13
 Section V Lubrication	 14
 Section VI Storage	 15
Short Term.....	15
Long Term	15
Restarting.....	16
 Section VII Button Bit Maintenance	 17
General	17
Sharpening.....	17
 Section VIII Patriot 240 Recommended Spares	 18



NUMA[®]
HAMMERS AND BITS
WARRANTIES AND REMEDIES

LIMITED WARRANTY

Numa warrants that the Product will be new and free from defects in material and workmanship under normal use as contemplated by this Contract for a period of six (6) months from the date of shipment.

Except for the foregoing warranty, Numa disclaims all warranties and representations wherever made, including warranties of merchantability, durability, length of service, or fitness for a particular purpose.

Any alteration or modification of the original product without the express written consent of Numa will void this warranty.

REMEDY

If, during such warranty period, Buyer promptly notifies Numa in writing of any defect and establishes that the above warranty is not met, Numa shall either repair or replace the Product or credit the customer, as it deems necessary to meet the warranty.

Such repair, replacement, or credit of Product shall constitute complete fulfillment of Numa's obligation under this warranty, and upon the expiration of the original warranty period, all of Numa's obligations hereunder shall terminate.

LIMITATION OF LIABILITY

Numa shall not be liable to Buyer whether in contract, in tort (including negligence and strict liability), under any warranty or otherwise, for any special, indirect, incidental or consequential loss or damage whatsoever, including (without limitation) loss arising from delay, cost or capital and loss of profits or revenues. The remedies set forth in this Contract are exclusive, and the total cumulative liability of Numa under this Contract or for any act or omission in connection therewith or related thereto, whether in contract, in tort (including negligence and strict liability), under any warranty or otherwise, is limited to the price paid by Buyer for the Product.

The **WARNINGS**, **CAUTIONS** and **NOTES** used throughout the text of this instruction book are defined as follows:

WARNING	A specific procedure or practice that must be strictly followed, or a specific condition that must be met, to prevent possible bodily harm.
CAUTION	A specific procedure or practice that must be strictly followed, or a specific condition that must be met, to prevent damage to the equipment.
NOTE	Important supplemental information.

Numa[®], Champion[®], and Patriot[®] are registered trademarks of Numa.

SECTION I DESCRIPTION

GENERAL DESCRIPTION

The Patriot 240 is a valveless, pneumatically operated tool designed to utilize Numa 24" to 36" (610 mm to 914 mm) diameter bits in rock formations under a wide range of operating conditions.

The Patriot 240 hammer design incorporates a non-reversible, hardened case. The single bore design allows for a maximum bore diameter in conjunction with optimum life against abrasion. The simple design of the Patriot 240 provides performance and dependability without sacrificing tool life.

The Patriot 240 is designed for universal applications using air pressure from 100 PSI to 200 PSI (6.8 Bar to 13.6 Bar) with compressors having capacities of 1900 CFM (897 Litres/Second) or more. When drilling conditions require supplementary hole cleaning, additional hole cleaning air can be passed through the hammer by utilizing an interchangeable choke. All standard hammers shipped from Numa have a blank choke installed. Refer to page 13 for correct choke selection and pages 6 and 11 to facilitate the removal and the installation of the choke. The Patriot 240 hammer is a high performance tool which may require additional downfeed to maximize performance. Please contact your local Numa Representative for further details.

<i>Patriot 240</i>		
Weight w/o Bit	5,109 lbs.	(2,317 kg)
Outside Diameter	20"	(508 mm)
Hammer Length:		
Shoulder to Shoulder	74-1/8"	(188 cm)
Shoulder to Bit Face	88-1/8"	(224 cm)
Backhead API Thread	8-5/8 API REG	

Table 1-1 General Hammer Specifications

24" (610 mm)	2174 lbs. (988 kg)	32" (813 mm)	3197 lbs. (1453 kg)
26" (660 mm)	2320 lbs. (1055 kg)	34" (864 mm)	3378 lbs. (1535 kg)
28" (711 mm)	2461 lbs. (1119 kg)	36" (914 mm)	3500 lbs. (1588 kg)
30" (762 mm)	2608 lbs. (1185 kg)		

Table 1-2 General Bit Specifications

NOTE

NUMA 24" TO 36" (610 MM TO 914 MM) BITS ARE AVAILABLE IN CONCAVE FACE DESIGN WITH LARGE AIR FLUSHING HOLES AND CHIP WAYS TO TAKE ADVANTAGE OF THE PATRIOT 240 PERFORMANCE. OTHER SIZES MAY BE AVAILABLE UPON REQUEST.

FUNCTIONAL DESCRIPTION

1. BACKHEAD



The backhead connects the hammer to the drill rod. It is threaded into the top end of the case with triple start threads and into the drill rod with a standard 8-5/8" API REG thread. Wrench flats are provided for disassembling.

2. PIN



The pin aligns the feed tube assembly into the backhead. It is made of hardened steel to insure long life.

3. CHECK VALVE



The check valve maintains pressure in the hammer when the air supply has been shut off. The pressure in the hammer balances the hydrostatic pressure in the hole thereby preventing contaminants from entering the hammer.

4. CHECK VALVE SPRING



The check valve spring provides tension under the check valve to keep it closed. It is compressed as the air is turned on.

5. CHOKE



The interchangeable choke is located in the tip of the feed tube and is held in place with a press fit. A set of two chokes is supplied with each hammer. By installing the correct choke, the hammer can be fine tuned to the compressor package.

6. PLUG



The plug is seated in the feed tube and maintains the proper location of the check valve and check valve spring.

7. FEED TUBE BUSHING



The feed tube bushing is seated in the feed tube, and maintains the proper location of the check valve and check valve spring.

8. FEED TUBE



The feed tube supplies the main air into the chambers located in the piston. It is connected to the backhead by the pin. The feed tube is designed with a long bearing surface to maintain alignment in the backhead.

9. PISTON



The piston functions as the only moving part in the hammer, controlling the operational air cycle. The percussive action of the piston striking the bit transfers the energy through the bit in order to fracture rock formations.

10. CASE



The case is designed to contain the internal parts which make up the hammer assembly. The case is non-reversible and hardened to resist wear and to extend life in abrasive conditions. Triple start threads on each end of the case allow for ease of disassembly.

11. BIT BEARING



The bit bearing guides the bit to insure proper alignment between the piston and the bit. The bit bearing is placed into the chuck end of the case and is located by a snap ring which is inserted into the main bore.

12. SNAP RING



A snap ring positions the internal parts in the hammer and prevents the piston from falling out when the chuck, bit retaining rings and bit are removed.

13. BIT RETAINING RINGS



The bit retaining rings are designed to allow the bit to move between the drilling and cleaning positions and prevent the bit from coming completely out of the hammer. The bit retaining rings consist of two matched halves and are held together with the bit retaining ring o-ring.

14. THRUST WASHERS - BRASS



Two brass thrust washers, one located between the backhead and the case and one between the chuck and the case, provide for easy disassembly.

15. CHUCK



The chuck threads into the bottom end of the case with triple start threads. It has internal splines that mesh with the splines on the bit body to transmit rotation.

16. CHUCK BUSHING



The chuck bushing is a nylon insert located in the bottom end of the chuck to provide a bearing surface between the lower bit shank and the chuck.

SECTION II MAINTENANCE

DISASSEMBLY

- If at all possible, the backhead and chuck should be broken loose on the drill rig; this is much easier than trying to do so after the drill has been removed from the drill rig. If not possible, see hammer breakout drawing Figure 2-1.

CAUTION

USE CAUTION WHEN HANDLING DOWN THE HOLE HAMMER PARTS. NUMA HAMMER PARTS ARE MANUFACTURED FROM HARDENED, HEAT TREATED MATERIALS. DROPPING OR STRIKING THESE PARTS MAY CAUSE SEVERE DAMAGE. STRIKING THE HAMMER PARTS WITH HAMMERS, CROWBARS OR LIKE INSTRUMENTS WILL VOID THE WARRANTY.

- Maintenance should be performed in a clean environment.
- Tools needed: hammer stand, 18-1/2" (470 mm) "J" or fork wrench (possibly incorporated in the hammer stand), overhead crane or lift truck, pulldown visetong with a 20" (508 mm) diameter capacity or a self contained power wrench capable of 150,000 foot pounds (20,700 Kgm) of torque, rubber mallet, 2" (51 mm) diameter brass rod or mild steel rod 3 to 5 feet (1 m to 1.5 m) long, a drift pin, a small screwdriver, a pry bar, and a nylon strap capable of lifting 10,000 lbs.
- Clean the outside of the hammer. This will insure a good surface to clamp on.
- Using an overhead crane or lift truck of appropriate capacity, place the hammer horizontally on a hammer stand and secure the hammer in the wrench. The chuck end can be held by the 18-1/2" (470 mm) flats, in the wrench. The backhead is also held in the 18-1/2" (470 mm) wrench except with the addition of flat stock between the wrench and the backhead flats (as the backhead flats are 17" (432 mm) across). Place the visetongs on the area of the case where the bit bearing is located when working on the chuck end of the hammer. When working on the backhead end of the hammer, place the chain vise on the acceptable clamping area of the case.

CAUTION

THE ACCEPTABLE CLAMPING AREAS START 11" (279 MM) FROM EITHER CASE END, TO AN ADDITIONAL 8-1/2" (216 MM) BEYOND THIS POINT. PLACING THE CHAIN VISE ON THE AREA OF THE CASE WHERE THE PISTON CYCLES CAN DISTORT THE CASE, RESTRICT PISTON MOVEMENT AND VOID THE WARRANTY.

- With the hammer standing in the vertical position, using an overhead crane and handling plug, unscrew and remove the chuck/bit assembly from the case.

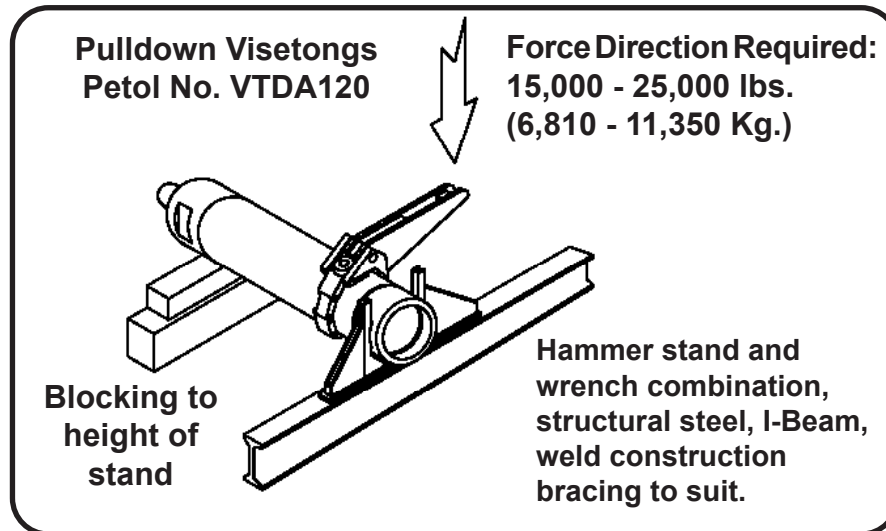

Hammer Breakout Drawing

Figure 2-1

- Remove the bit retaining rings from around the bit.
- Remove the o-ring from the bit retaining rings.
- Remove the chuck from the bit.
- Remove the drive plates from the bit and chuck splines.
- Remove the brass thrust washer from the chuck.
- Using the overhead crane and handling plug, unscrew the backhead / feed tube assembly from the case.
- Place the hammer horizontally on a hammer stand and secure the hammer with a chain vise.
- With the case in a horizontal position and using a 2" (51 mm) diameter brass rod, slide the piston out of the backhead end of the case. Using the nylon strap and overhead crane, remove the piston from the case.
- Removal of the chuck bushing is not necessary for routine maintenance. If necessary, lay the chuck on its side so that the bit end is facing you. Locate the seam in the chuck bushing. Insert a screwdriver into the slot in the middle of the seam and pry the chuck bushing from the under cut. Remove the chuck bushing from the bit end of the chuck.

- Removal of the bit bearing and snap ring from the chuck end of the case is not necessary for routine maintenance. If necessary, locate the disassembly notch where the snap ring is located. Using a pry bar, pry the snap ring out of the groove, and remove from case. Using a 2" (51 mm) diameter brass rod, go into the case from the backhead end, tapping the bit bearing out of the chuck end of the case.
- To disassemble the backhead / feed tube assembly, lay the backhead / feed tube assembly on a workbench.
- Using a drift pin, tap the pin out of the backhead/feed tube assembly.
- Using the 2" (51 mm) diameter brass rod, go through the API thread end of the backhead, and tap the feed tube assembly out.
- Remove the check valve and check valve spring from the feed tube assembly.
- Removal of the plug, choke, and feed tube bushing are not necessary for routine maintenance. If necessary, use a 1/2" (13 mm) diameter, 36" (914 mm) long rod and tap the choke downward, toward the plug. Continue tapping the plug, choke, and feed tube bushing out of the feed tube.
- Remove the o-ring from the groove located on the outside diameter of the feed tube.
- Remove the brass thrust washer from the backhead.
- Remove the backhead o-ring from the backhead outside diameter.

INSPECTION

- All parts should be washed in a clean solvent before they are inspected and reassembled.

WARNING
USE CLEANING FLUIDS THAT ARE NONFLAMMABLE AND AVOID
BREATHING THE FLUID VAPORS.

- Handle all parts carefully, hardened parts may chip if dropped on a hard surface.

BACKHEAD

- Inspect the threads and pin hole for cracks and burrs.
- Remove all burrs on the thread with a fine file or emery cloth.
- Replace if necessary.

CHECK VALVE - ALUMINUM

- The check valve should be smooth and free from abrasions.
- Replace if necessary.
- Replace the check valve spring if it is worn or broken.

FEED TUBE ASSEMBLY

- Inspect the outside diameters for nicks, burrs and scoring.
- Inspect all makeup surfaces for indentations or nicks caused by wear.
- Remove all minor irregularities with emery cloth.
- Replace if necessary.

PIN

- Inspect pin for scoring or cracks.
- Replace if necessary.

SNAP RING

- Inspect the snap ring for severe wear indications.
- Remove or round over any sharp edges.
- Replace if necessary.

PISTON

- Inspect the striking face, inside and outside diameters for nicks, scoring and cracks.
- Polish the piston with emery cloth to remove all minor irregularities, cracked pistons should be replaced.
- Wash the piston thoroughly, inside and out, to remove all emery dust.

CASE

- Inspect the outside diameter for excessive wear or cracks. Inspect the internal case bore for scoring.
- Remove all minor irregularities with fine honing stones.
- Clearance between the case and piston should not exceed .024 (0.61 mm).
- Replace if the outside diameter is worn to 19-1/4" (489 mm) or less near the chuck end.

BIT BEARING

- Inspect the inside and outside for nicks and burrs.
- Remove all internal irregularities with a polishing wheel.
- Remove all external irregularities with an emery cloth.
- Clearance between the bit bearing and the bit shank should not exceed .048 (1.22 mm).
- Replace if necessary.

BIT RETAINING RINGS

- Inspect for cracks or deformations.
- Remove all irregularities with a file or emery cloth.
- Replace if necessary.

CHUCK

- Inspect the chuck bushing for cracks or irregularities. Replace if necessary.
- Inspect for cracks and burrs.
- For continued use, the outside diameter should be larger than the outside of the case or the same. Collar length should not be less than 5-3/8" (137 mm).

CAUTION

IF THE COLLAR LENGTH IS LESS THAN 5-3/8" (137 MM) AND THE BIT IS UNDER LOAD CONDITIONS, CONTACT BETWEEN THE SHOULDER OF THE BIT RETAINING RINGS AND THE BOTTOM OF THE BIT RETAINING RING AREA ON THE BIT, COULD CAUSE THE BIT TO FAIL IN THIS AREA.

- Torsional play in the splines should not exceed .375" (9.53 mm).
- Replace if necessary.

O-RINGS

- Inspect for damage such as cracks and deformations.
- Replace if necessary.

THRUST WASHERS - BRASS

- Inspect for damage such as cracks and deformations.
- Replace if necessary.

GENERAL ASSEMBLY INSTRUCTIONS

- Assembly should be performed in a clean environment.
- All parts should be cleaned thoroughly and wiped dry before assembly.
- Oil all parts by hand using Rock Drill Oil to insure easy assembly.
- Coat all thread connections with a thread compound to allow joints to thread easily.

HAMMER ASSEMBLY

- Using the 2" (51 mm) brass rod, tap the slip fit bearing into the chuck end of the case.
- Using a pry bar, install the snap ring into the snap ring groove located against the bit bearing.
- Install the chuck bushing in the chuck. With the bit face down, place the chuck over the top of the bit. Align the splines and lower chuck completely onto the bit. Rotate the chuck counterclockwise until the splines meet and insert the drive plates between the chuck and bit splines. See Figure 2-3.
- Place the bit retaining rings, with the bit retaining ring o-ring installed, over the bit shank and on top of the chuck.

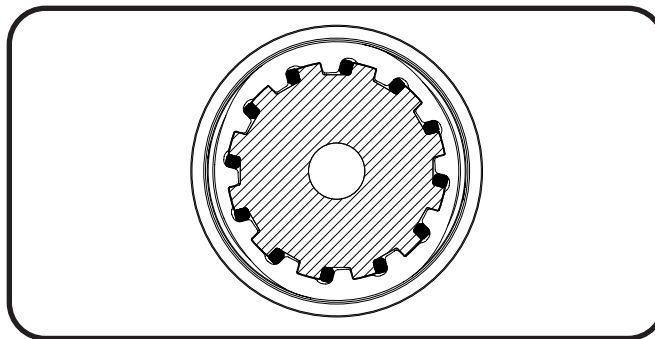

*Drive Plate Positioning as Viewed from Top of Chuck
Figure 2-3*

- Place the brass thrust washer over the chuck until it seats against the shoulder.
- Slide the piston in the backhead end of the case. Push the piston all the way to the chuck end. The piston should ride in the case very smoothly.

BACKHEAD / FEED TUBE ASSEMBLY

- Place the backhead on its side on the bench. Install the backhead o-ring into the groove located on the outside thread diameter.
- Place the thrust washer over the backhead until it rests against the backhead shoulder.
- Install the feed tube o-ring into the groove located on the outside of the feed tube.
- Drop the choke into the feed tube, and using the 1/2" (13 mm) diameter rod, tap the choke into place.
- Using a drift pin, tap the plug into the feed tube until it seats against the shoulder.
- Insert the feed tube bushing into the feed tube until it rests against the plug.
- Install the check valve spring and check valve into the feed tube.
- Using a rubber mallet, tap the feed tube into the backhead, aligning the hole in the feed tube with the hole in the backhead.
- Using a rubber mallet, tap the pin into the hole.
- Using an overhead crane, stand the case up in a vertical position with the chuck end on the ground.
- Using an overhead crane and a handling plug, lower the backhead / feed tube assembly into the case. Thread the backhead / feed tube assembly into the case until it shoulders up against the thrust washer.
- Using an overhead crane and a handling plug, lift the hammer over the bit and chuck assembly. Lower the hammer onto the chuck, and thread together until it shoulders up against the thrust washer.

CAUTION

DUE TO CLOSE TOLERANCES BETWEEN THE PATRIOT 240 INTERNAL PARTS AND THE CASE, NUMA CAN NOT ACCEPT RESPONSIBILITY FOR DAMAGE CAUSED BY WELDING ON THE CASE OD. WELDING ON THE CASE CAN CREATE DISTORTION, CAUSE PREMATURE FAILURE AND VOID THE WARRANTY. CONTACT NUMA FOR SPECIAL INSTRUCTIONS IF WELDING THE CASE BECOMES UNAVOIDABLE.

SECTION III PARTS IDENTIFICATION EXPLODED VIEW

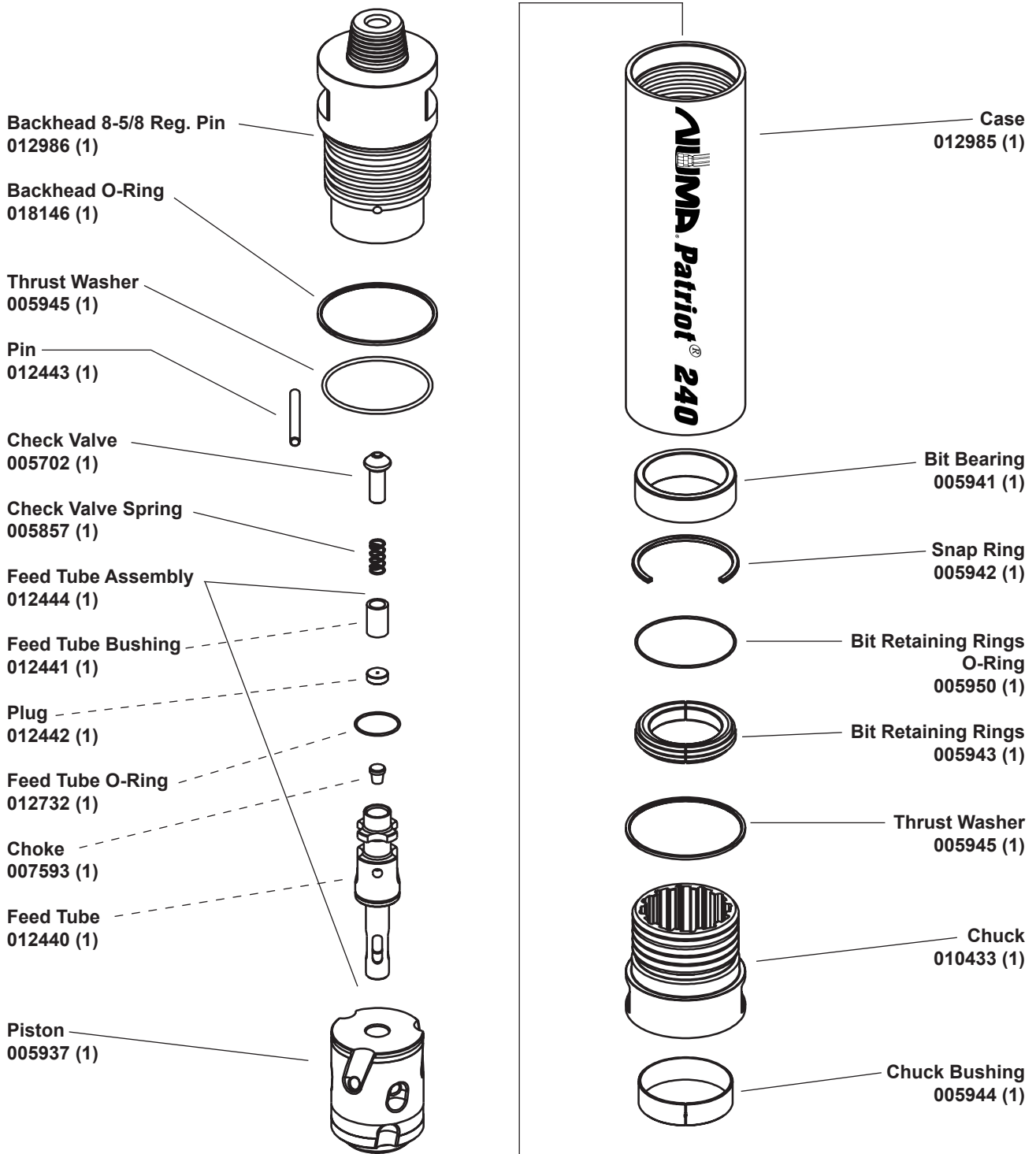

HAMMER ASSEMBLY #013987

Figure 3-1

SECTION IV AIR CONSUMPTION CHARTS PATRIOT 240

DRILL PRESSURE (BAR)

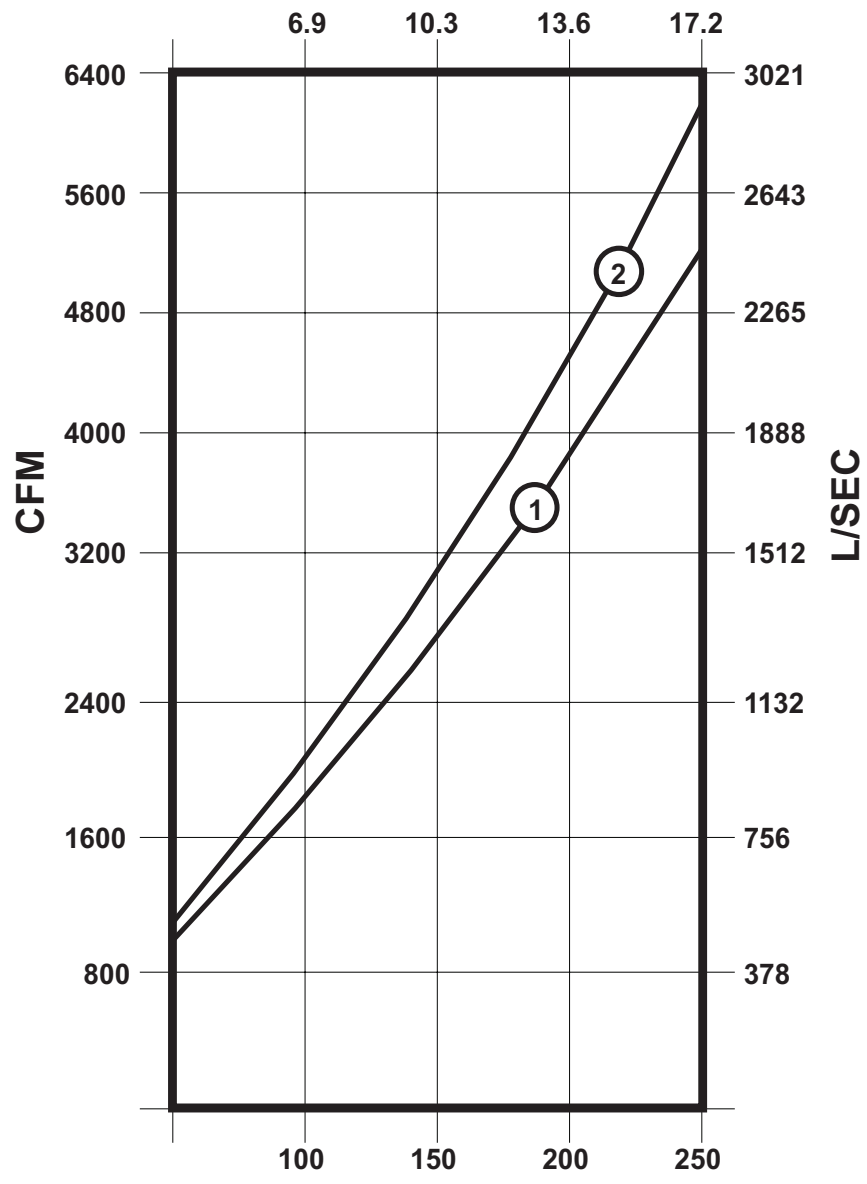

DRILL PRESSURE (PSI)

- ① SOLID CHOKE
- ② 1/2 (12.7mm) CHOKE

SECTION V LUBRICATION

The Patriot 240 hammer requires a continuous supply of the correct type Rock Drill Oil. The Patriot 240 hammer consumes at least twelve quarts (11.4 litres) of Rock Drill Oil per hour in order to maintain adequate lubrication. See table 5-1 for recommended Rock Drill Oil.

	Medium SAE 30	Heavy SAE 50
Shell	Air Tool Oil S2 A 150	Air Tool Oil S2 A 320
Texaco / Caltex	Rock Drill Lube 100	Rock Drill Lube 320
Chevron	Vistac 150	Vistac 320
Conoco	Conoco 150	Conoco 320
Numa Bio Blend	RDP 150	RDP 320

Table 5-1
Recommended Rock Drill Oil

CAUTION

ROCK DRILL OILS ARE THE ONLY ACCEPTABLE LUBRICANTS. SAE 50 ROCK DRILL OIL SHOULD BE USED IN AMBIENT TEMPERATURES OF 80° FAHRENHEIT (27° CELSIUS) OR HIGHER. CONTACT NUMA FOR ACCEPTANCE OF ALTERNATIVE ROCK DRILL LUBRICANTS.

CAUTION

THE PATRIOT 240 HAMMER, AS WITH ANY MACHINE, REQUIRES CONTINUOUS LUBRICATION. THE FAILURE TO SUPPLY ADEQUATE LUBRICATION TO THE HAMMER CAN CAUSE PREMATURE FAILURE AND MAY VOID THE WARRANTY.

SECTION VI STORAGE

When storing a Patriot hammer, it is important to take the necessary steps in order to insure a smooth operation after restarting.

When the hole is completed and the hammer is to be inactive for several weeks or longer the following steps should be followed:

Each drill rod should be blown clear of all water. During this process, turn on the in line lubricator and blow until the rock drill oil can be seen from the bottom end of each drill rod. In addition, each rod (pin and box end) should be wiped clean and capped to prevent foreign contaminants from sticking to the connector ends.

SHORT TERM STORAGE

When the Patriot hammer will be stored for only a short period of time the following steps should be taken:

- Blow the hammer clear of all water.
- Pour one cup of Rock Drill Oil into the backhead.
- Turn the air on and cycle for 10 seconds. This will lubricate the internal parts.
- Cap the backhead and chuck end.
- Store the hammer horizontally in a dry environment.

LONG TERM STORAGE

When the Patriot hammer will be stored for a long period of time the following steps should be taken:

- Blow the hammer clear of all water.
- If at all possible, the backhead and chuck should be broken loose on the drill rig, this is much easier than trying to do so in the shop.
- Disassemble the hammer.
- Inspect and wipe all the parts clean.

- Lubricate all the internal parts with Rock Drill Oil. See table 5-1 on page 14 for suitable Rock Drill Oils.
- Cap the backhead and chuck ends.
- Store the hammer horizontally in a dry environment.

RESTARTING

Before restarting the hammer after prolonged periods of inactivity, disassemble and inspect all internal hammer parts.

If any internal hammer parts have oxidized, use an emery cloth to polish each part. Wash each hammer part, wipe dry, relubricate with rock drill oil and reassemble the hammer.

CAUTION

**FAILURE TO CHECK INTERNAL PARTS BEFORE RESTARTING THE HAMMER
MAY CAUSE SERIOUS DAMAGE TO THE HAMMER.**

SECTION VII BUTTON BIT MAINTENANCE

GENERAL

Numa button bits are designed for fast penetration and long life. Keeping the carbide buttons sharp has a direct effect on both the penetration and the tool life.

As the bit wears flat, spots develop on the carbide buttons. These flat spots increase stress on the buttons causing the bit to work harder, which may cause button failure. Bit sharpening can minimize these problems.

Gauge buttons will usually show the most wear and should be used to determine the frequency of bit sharpening. When the flats on the gauge buttons become a maximum of 1/8" (3 mm) wide it is time to resharpen. Refer to figure 7-1.

SHARPENING

The following tools are required to resharpen the bit:

- Hand grinder (20,000 r.p.m.)
- Silicon carbide wheel 1" (25 mm) diameter, 60 - 80 grit
- Bit stand
- Pencil

Place a mark on the center of the button flat. Grind the button to its original shape leaving the mark untouched. Refer to figure 7-1. It is important to leave the center of the flat untouched to insure concentricity.

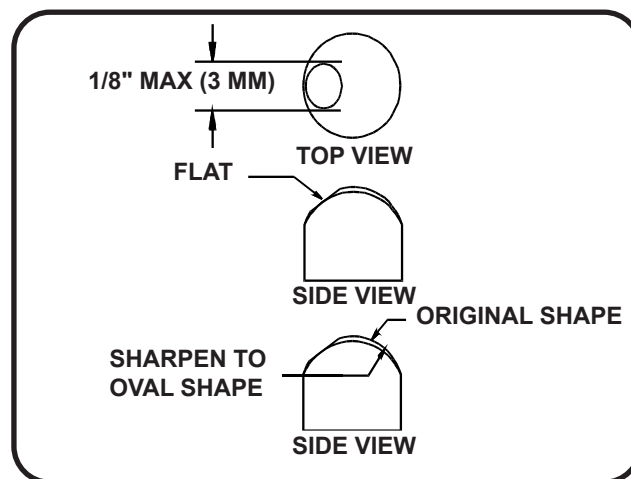

Button Resharpening
Figure 7-1

SECTION VIII RECOMMENDED SPARES Patriot 240

Product Description	Part Number	Class 1	Class 2
Backhead 8-5/8 Reg. Pin	012986	0	1
Backhead O-Ring	018146	1	2
Pin	012443	1	2
Thrust Washer	005945	2	4
Check Valve	018121	1	2
Check Valve Spring	018122	1	2
Feed Tube Assembly	012444	1	2
Feed Tube Bushing	012441	0	1
Plug	012442	1	2
Choke Blank	007593	0	1
Feed Tube O-Ring	012732	1	2
Feed Tube	012440	1	2
Piston	005937	0	1
Case	012985	0	1
Bit Bearing	005941	0	1
Snap Ring	005942	0	1
Bit Retaining Rings	005943	0	1
Bit Retaining Rings O-Ring	005950	1	2
Chuck	010433	0	1
Chuck Bushing	005944	1	1
Choke Set	007307	1	2
Choke Blank - installed in hammer	007593	0	1
Choke 1/2"	007594	0	1

For Complete Hammer Assembly #013987
Table 8-1

NOTE

- Class 1** Represents a user of a Patriot 240 hammer that has readily available spare parts.
- Class 2** Represents a user of a Patriot 240 hammer that does not have readily available spare parts.

NOTES

NOTES